



Download “How to use and maintain your Hitch-Ezy” from the Technical tab at: www.hitch-ezy.com.au

FITTING INSTRUCTIONS

- The towing vehicle and the tow-bar must be rated to handle the intended use.
- Maximum draw bar weight at rest: 500kg for 5 tonne model; 350kg for 3.5 tonne model.
- With the 5 tonne model the D-value (30.2 kN) and V-value (16.1 kN) must be adequate for the intended tow-vehicle/ trailer combination.
- If towing above 4.5 tonne the installation on both the truck and the trailer must be approved by an accredited person as per National Heavy Vehicle regulations.

A) Fitting the tow-pillar.

Mounting the tow-pillar on a tow-bar tongue:

1. The correct sequence of parts is depicted in the diagram. **NB . Do not modify the stainless steel specification plate.** The correctly fitted plate establishes that the coupling can come to a jackknife position without fouling anything on the vehicle side of the ball-mount hole.
A suitably dimensioned tow-bar tongue must be used.
2. The diameter of the tow-pillar’s shank must match the diameter of the ball-mount hole in the tow-bar tongue.
3. Torque a 7/8” shank nut to 300Nm (225ft/lbs) and a 1 ¼” shank nut to 500Nm (375ft/lbs).
4. Tow-pillar rotation during nut tightening can be controlled by engaging the supplied tommy bar in the hole in the tow-pillar’s neck.

Mounting the tow-pillar on a weight distribution hitch (WDH):

1. Hitch-Ezy is compatible with most WDHs. **The safe towing capacity of the combined WDH and coupling is that of the lowest rated component.**
2. The correct sequence of the parts is depicted in the diagram.
3. The diameter of the tow-pillar’s shank must match the diameter of the ball-mount hole in the WDH’s head.
4. The **spacer** which is optional on a tow-bar tongue **must** be used when the tow-pillar is mounted on a WDH head.
5. Torque a 7/8” shank nut to 300Nm (225ft/lbs) and a 1 ¼” shank nut to 500Nm (375ft/lbs).
6. Confirm that the coupling will not foul on the WDH head or the drop shank when turning. The range of unimpeded articulation is best assessed by connecting the coupling to the tow-pillar mounted on the WDH head before the coupling is bolted to the trailers draw-bar.
7. Once the coupling is fitted to the draw-bar confirm that the draw-bar itself does not foul the WDH head when the trailer is at a jackknife position.

Never modify a WDH. Never weld to a cast WDH. Follow the WDH manufacturer’s instructions.

B) Mounting the coupling’s body onto the trailer’s draw-bar:

1. Use the supplied high tensile bolts as depicted in the diagram. Do not weld to the draw-bar.
2. Bolt length must ensure 100% thread engagement of the nut.
3. Torque nuts to bolt manufacturer’s specification; typically 100Nm or 75 ft/lbs dry.
4. Use all bolt holes. Using only two bolts in the front holes and two in the rear holes on the 5 tonne model reduces its rated towing capacity to 3.5 tonne.

Fitting 3.5 tonne to draw bar

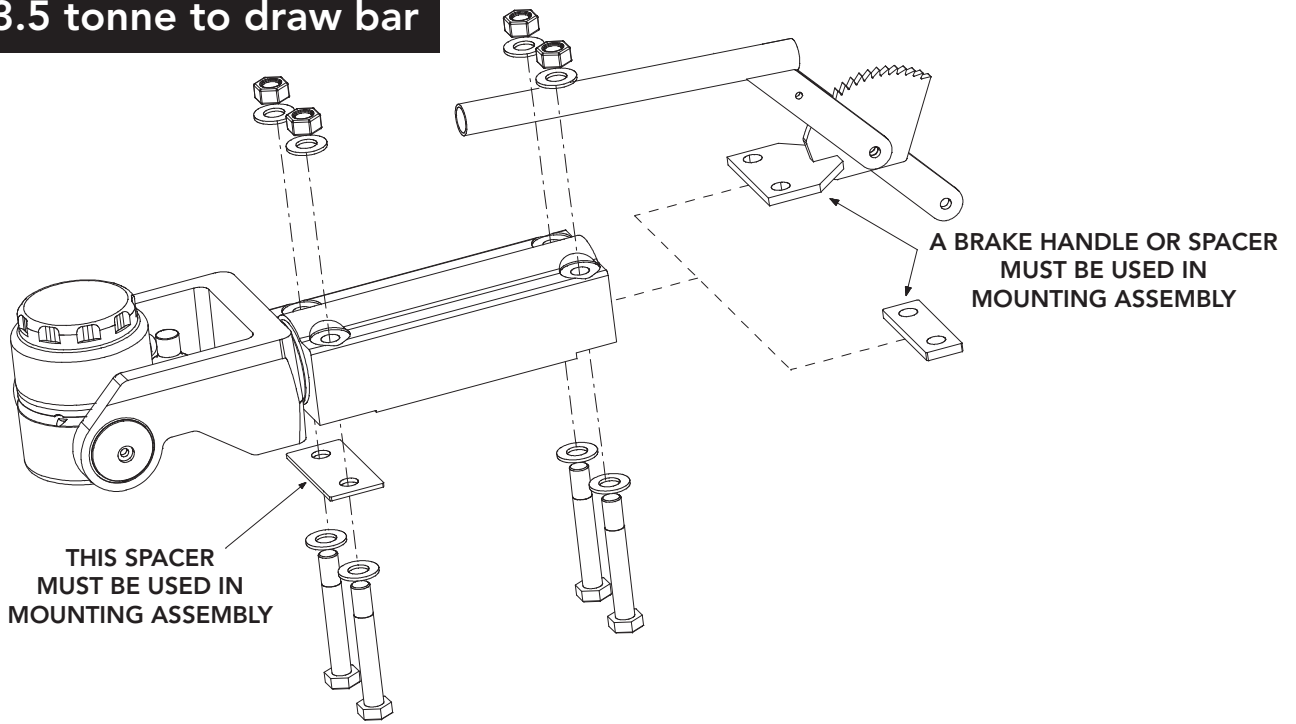

Fitting 5 tonne to draw bar

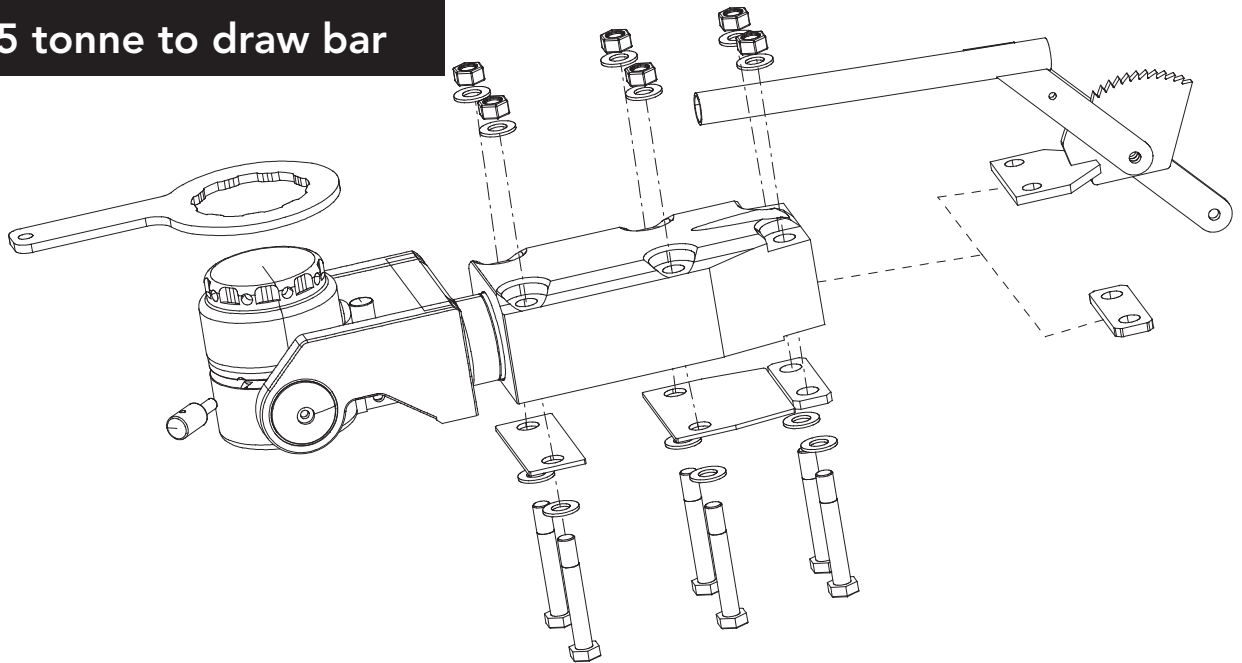

Fitting to Pillar

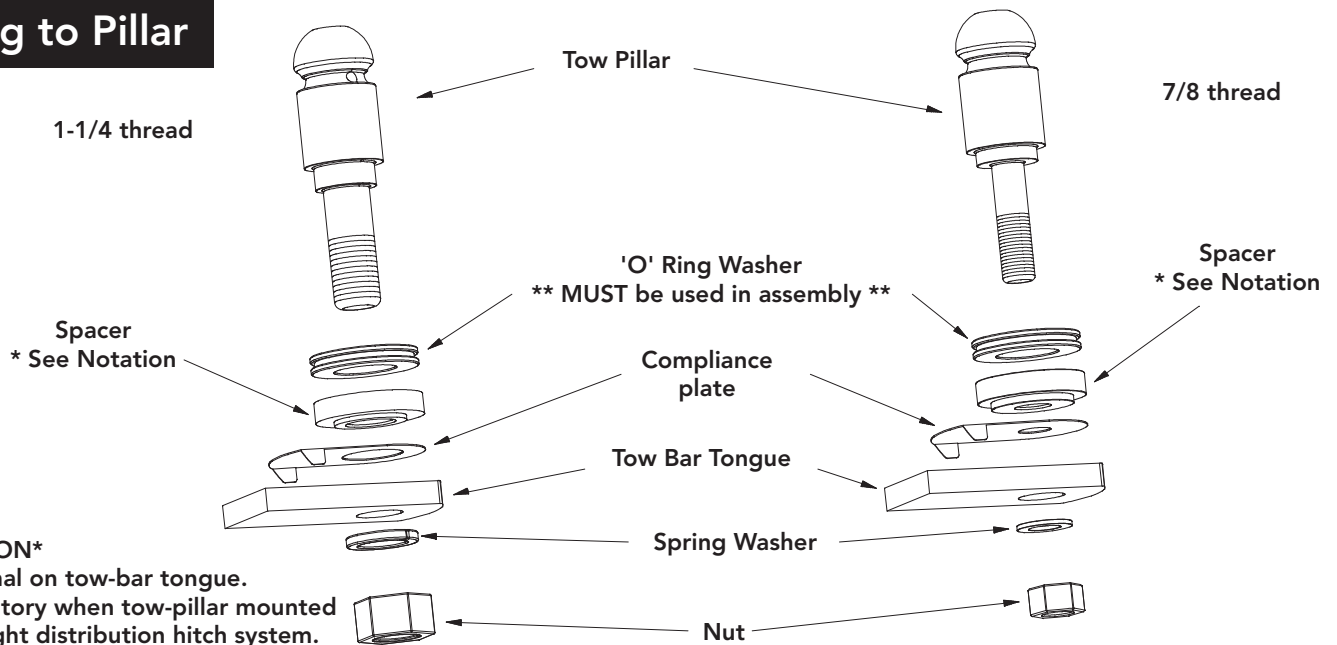

NOTATION

- 1) Optional on tow-bar tongue.
- 2) Mandatory when tow-pillar mounted on a weight distribution hitch system.